

# TEAMWORK GLOBAL GROUP LIMITED

## 电机确认书 MOTOR APPROVAL SHEET



客户物料编号:  
CUSTOMER CODE NO :

产品名称:  
MACHINE NAME:

咖啡磨豆机

产品型号:  
MACHINE TYPE:

电机型号:  
MOTOR TYPE:

7035M23-EMC-F(铜线)

电压/频率:  
VOLT/FREQ:

220-240V/AC 50/60Hz

版本:  
VERSION:

A/0

日期:  
DATE:

2019.11.23.

制表:  
DESIGNED BY:

审核:  
CHECKED  
BY:

批准:  
APPROVED BY:

客户确认签名:  
CUSTOMER APPROVED SIGNATURES

此为正式生产确认数据,我方将严格按照此技术数据批量生产

This is formal technical data,all mass order production will be followed exactly according to this approved technical file

1 OF 3 Page

SHENZHEN BAOAN DISTRICT SONGGANG STREET GOLD OPEN 11 EAST MATTERS B24B BUILDING

Tel:0086-0755-85265699

Fax:0086-0755-85266599

第1页

# TEAMWORK GLOBAL GROUP LIMITED

SHENZHEN BAOAN DISTRICT SONGGANG STREET GOLD OPEN 11 EAST MATTERS B24B BUILDING

Tel:0086-0755-85265699

Fax:0086-0755-85266599

## 电机性能测试报告 Performance test report

第2页

电机型号 Motor Model:		7035M23-EMC-F(铜线)		额定电压 / 频率 rated Voltage/Frequency		230VAC 50Hz		项目编号 Item No.		咖啡磨豆机				
序号	检测项目 Item		标准 Standard	测试结果 Results										
				1	2	3	4	5	6	7				
1	电气特性 Electric characteristics	空载 Free load	电流 Current	0.485±15%(A)	0.496	0.469	0.495	0.453	0.481	0.499	0.502			
2			功率Power	110±15%(W)	113	107	113	103	110	114	115			
3			转速Speed	17300±15%(rpm)	17300	17200	17800	17100	17000	17000	17200			
4			火花Spark	≤1.5 (class)	√	√	√	√	√	√	√			
5		负载 On load	负载风叶 Fan onload	37.5x90(A5)	√	√	√	√	√	√	√			
6			电流 Current	1.2±10%(A)	1.224	1.17	1.222	1.154	1.201	1.19	1.22			
7			功率Power	260±10%(W)	266	252	268	250	260	258	265			
8			转速Speed	10100±10%(rpm)	10000	10000	10180	10300	10000	10000	10000			
9			火花Spark	≤2 (class)	√	√	√	√	√	√	√	√		
10	机械特性 Machine characteristics	转向 Rotation	CW	√	√	√	√	√	√	√				
11		轴伸 Extension	34.5±0.5 (M左x6.5)	√	√	√	√	√	√	√				
12		虚位 End play	0.5~1.3mm	√	√	√	√	√	√	√				
13		噪音 Noise	≤90 (dB-1000mm)	√	√	√	√	√	√	√	√			
14		振动 Vibration	≤20 (mm/s)	√	√	√	√	√	√	√	√			
15	安全性 Safe	高压测试 Hi-pot test	1500VDC / 5mA / 1SEC	√	√	√	√	√	√	√				
16		绝缘电阻 Insulation resistance	冷态Cold Conditions≥50 (MΩ) 热态Hot Conditions≥5 (MΩ)	√	√	√	√	√	√	√	√			
17		绝缘等级 Insulation Class	F	√	√	√	√	√	√	√	√			

制表DESIGNED BY :

审核CHECKED BY:

批准 APPROVED BY:

电源线: E204893 22AWG 1015# 105°C 可复位温度保护器: KW-105°C 5A 250V (金属壳)

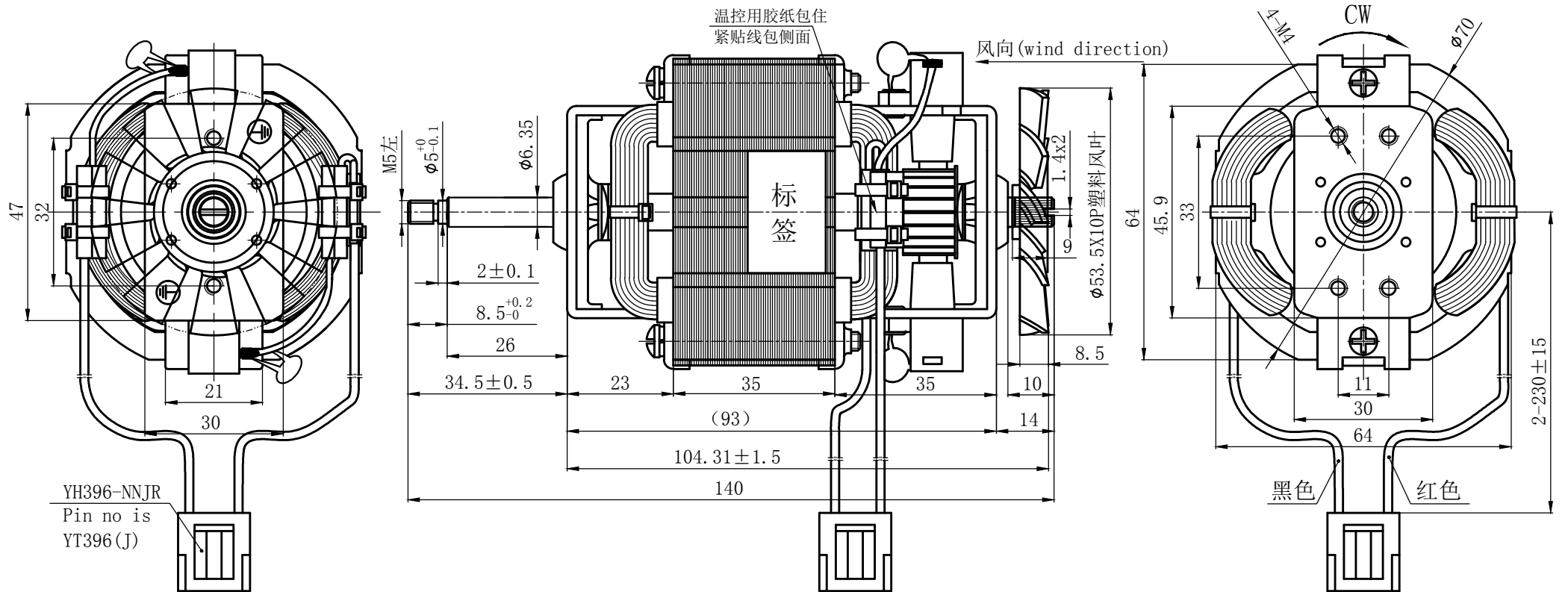

电机外观要求: Motor Appearance requirement:

- 1、电机轴表面光亮、无损伤、无锈迹。  
Motor shaft surface brightness, no scratch & rust"
- 2、螺丝紧固、不松动, 松脱扭力 $\geq 5\text{Kgf} \cdot \text{cm}$ , 碳套不松动, 安装螺孔标准。  
Screw tighten, unfasten torque  $\geq 5\text{Kgf} \cdot \text{cm}$ ; No loosen brush cage."
- 3、引线拉脱力 $\geq 3\text{Kg}$ 。  
Leadwire pull-out force  $\geq 3\text{Kg}$ "
- 4、尼龙扎带绑扎牢固, 温控器与线圈贴合紧密。  
Nylon cable ties fastened, Thermal protector fit tight with winding"
- 5、定子线圈包扎紧固, 浸漆均匀, 无漆瘤。  
Stator winding tighted, Insulation varnish evenly distributed."
- 6、电机外观良好, 铁芯无锈斑、伤痕、残缺; 无变形。  
Motor Appearance good, no rust, scratch and deformation allowed."
- 7、接地符号标识清楚, 电机印章或铭牌字体工整、清晰。  
The Grounding mark clearly, motor label clearly"
- 8、耐久寿命测试: 额定电压下负载250W左右, 开2分停1分工作时间大于100个小时!  
Endurance test (under rated power 250W with two minutes on, one minute off) Over 100 hours!

标签内容 (label)

HC7035M23  
220-240VAC/50-60Hz  
CLASS: F  
2019-XX-XX

电气原理图

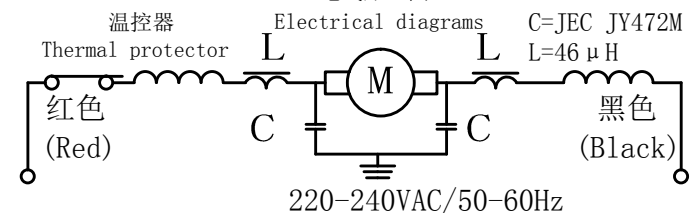

2		一般尺寸公差 $X \pm 0.2$ $X.X \pm 0.1$ $X.XX \pm 0.05$	TEAMWORK GLOBAL GROUP LIMITED
1		角度 $\pm 20'$ 圆角和倒角 0.5	
CHG	DESCRIPTION	MATERIAL	品名: 7035M23-F级-EMC-
修改	说明		咖啡磨豆机电机外形图
DRAWN		SCALE A4	品号:
绘制			UNIT mm
CHECKED		SIZE A4	页次: 3
校对			版本: A/0
APPROVED			
批准			